

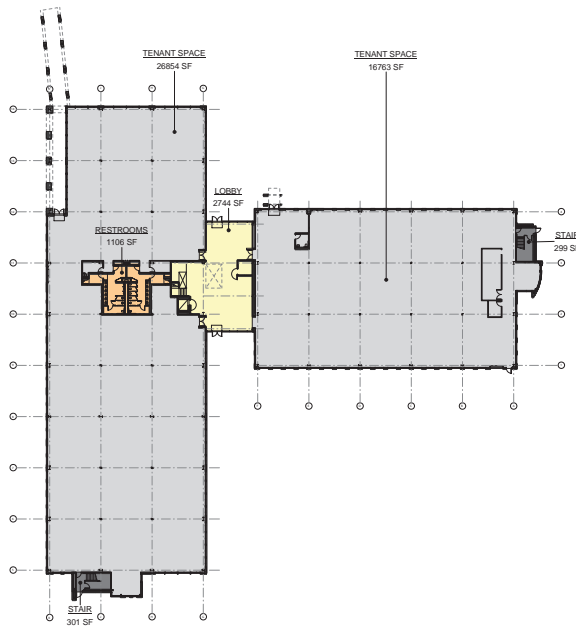

Building 10
7500 Gateway Blvd

Total Office Area
± 126,721 SF



First Floor:
± 48,067 SF

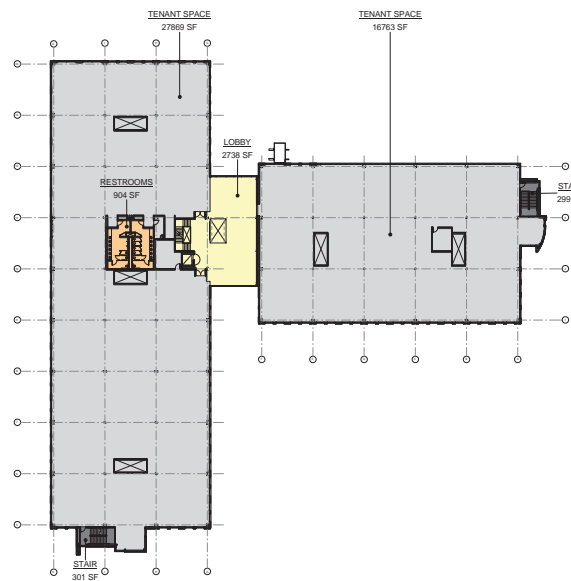

Second Floor:
± 48,874 SF

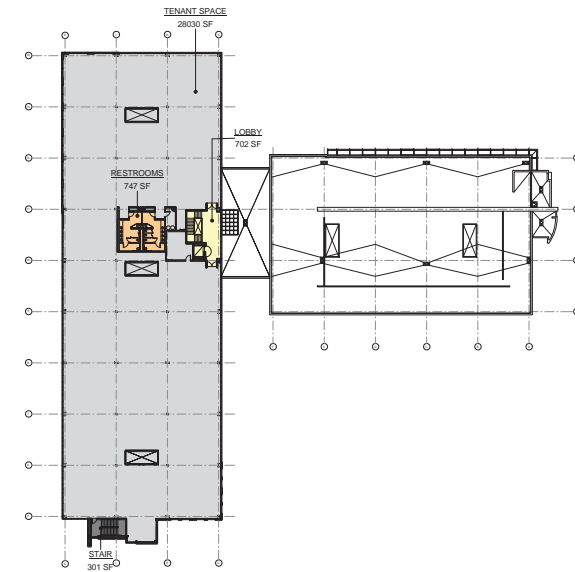

Third Floor:
± 29,780 SF

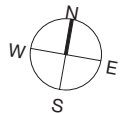

Owned and managed by:



For lease information call:

Gregg Domanico or Steve Bouret
415.229.8888
www.pacificresearchcenter.com

